

# Air Heaters



## Finned Heaters

### 375 Finned Strip Heaters

375 finned strip heater is constructed of highly-compacted magnesium oxide (MgO) based insulation, which conducts heat efficiently from the nickel chromium element wire to the sheath. Two-inch wide (51 mm) nickel plated fins are attached to maximize surface contact allowing heat to transfer into the air faster. Lower sheath temperature and element life are maximized by this finned construction.

### Performance Capabilities

- Aluminized steel sheath temperatures up to 1100°F (595°C)
- Watt density up to 33 W/in<sup>2</sup> (5.1 W/cm<sup>2</sup>)
- UL<sup>®</sup> approved up to 240VAC (File No. E52951)
- CSA approved up to 600VAC (File No. LR7392)

### Features and Benefits

#### Nickel chromium element wire is centered in the heater

- Uniformly heats the strip

#### Aluminized steel sheath

- Operates at higher temperatures
- Resists corrosion more effectively than iron-sheathed heaters

#### Optional 430 stainless steel sheath

- Provides a durable solution for highly corrosive environments

#### Welded post terminals

- Produces strong, trouble-free connections

#### Available lengths from 5<sup>1</sup>/<sub>2</sub> to 48 in. (140 to 1220 mm)

- Fits a variety of application needs

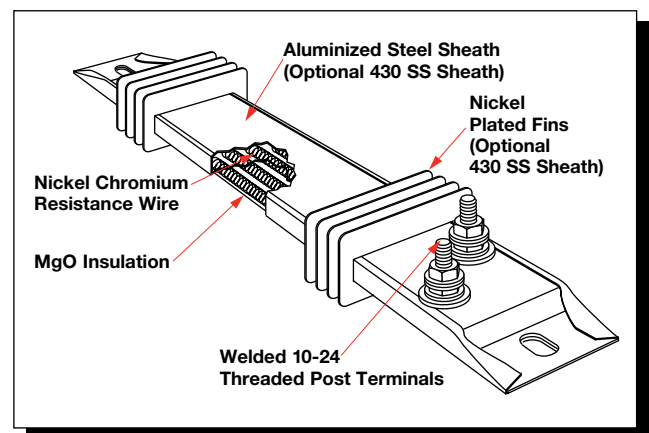

### Typical Applications

- Enclosure heating
- Load bank resistors
- Shrink tunnels
- Duct heaters
- Space heaters
- Drying ovens
- Incubators
- Air heating
- Heat curing
- Ink drying
- Food warmers
- Moisture protection
- Dehumidifiers
- Stress relieving ovens

# Air Heaters



## Finned Heaters

### 375 Finned Strip Heaters

#### Applications and Technical Data

#### Calculating Watt Density

Use the graph and formulas to ensure that the maximum allowable watt density for the heater is not exceeded in the application.

Open air watt density is calculated for the total heated surface area.

#### Formulas

$$\text{Watt Density} = \frac{\text{Wattage}}{\text{Heated Area}}$$

$$\begin{aligned} \text{Heated Area} \\ (\text{Offset Terminals}) &= [\text{Overall Length (A)} - 4 \text{ in.}] \\ &\quad \times 3.75 \text{ in.} \\ &= [\text{Overall Length (A)} - 102 \text{ mm}] \\ &\quad \times 95.3 \text{ mm} \end{aligned}$$

$$\begin{aligned} \text{Heated Area} \\ (\text{Parallel Terminals}) &= [\text{Overall Length (A)} - 3.12 \text{ in.}] \\ &\quad \times 3.75 \text{ in.} \\ &= [\text{Overall Length (A)} - 79.3 \text{ mm}] \\ &\quad \times 95.3 \text{ mm} \end{aligned}$$

$$\begin{aligned} \text{Heated Area} \\ (\text{One-on-One Terminals}) &= [\text{Overall Length (A)} - 4.25 \text{ in.}] \\ &\quad \times 3.75 \text{ in.} \\ &= [\text{Overall Length (A)} - 108 \text{ mm}] \\ &\quad \times 95.3 \text{ mm} \end{aligned}$$

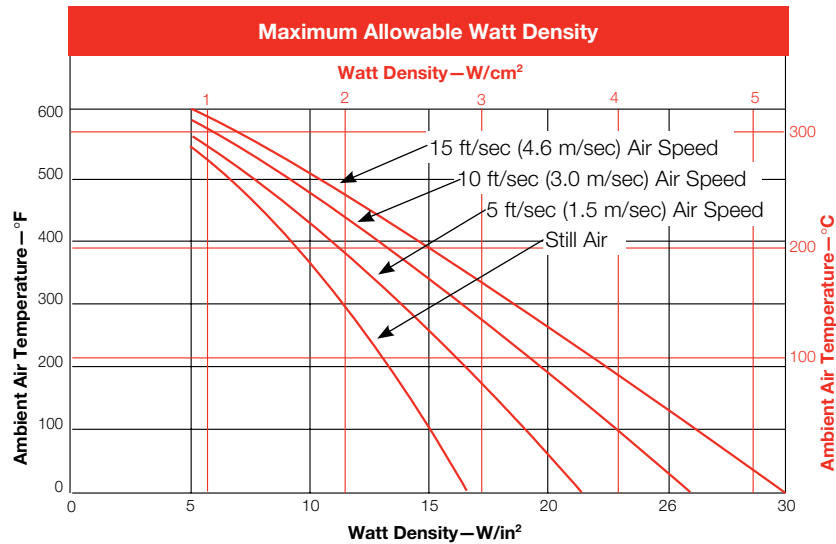

# Air Heaters



## Finned Heaters

### 375 Finned Strip Heaters

#### Termination Options

#### Offset Terminals

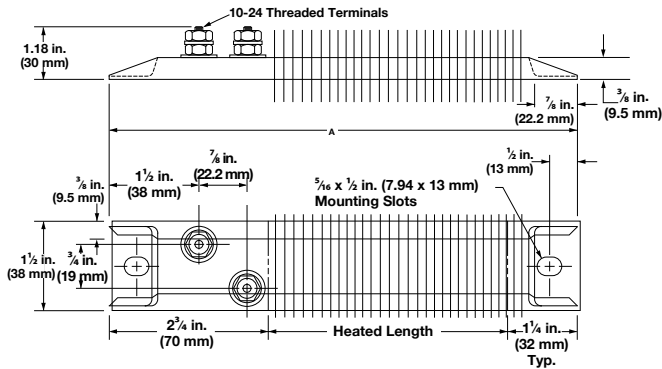

Two 10-24 threaded post terminals are offset from each other on the same end.

#### One-on-One Terminals

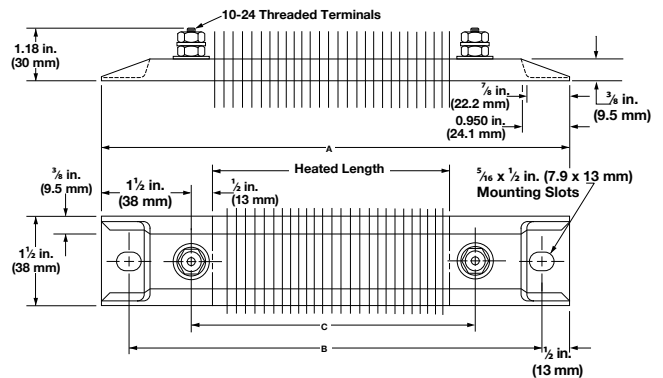

Two 10-24 threaded post terminals are placed one on each end.

#### Parallel Terminals

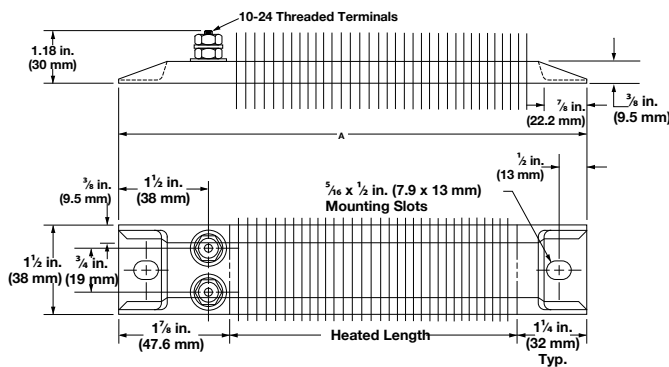

Two 10-24 threaded post terminals are used; both terminals on one end.

#### In-Line Terminals

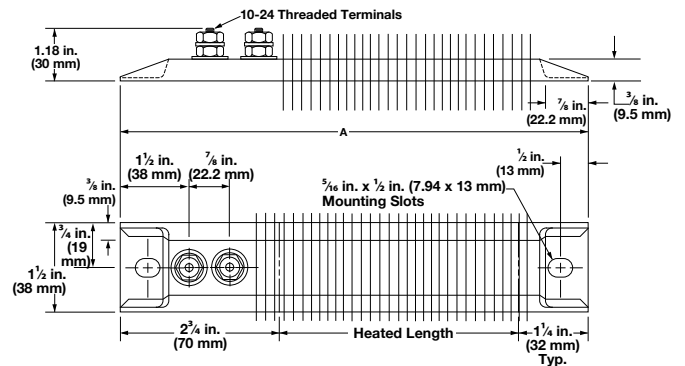

Two 10-24 threaded post terminals are in-line with each other on the same end.



Sales@ptsheat.com

Dave Farmery  
Ben Midulla

Toll Free Phone/Fax

844-787-4328  
844-PTS HEAT

www.PhoenixThermalSupply.com

CONTACT: SALES@PTSHEAT.COM; 844-787-4328

# Air Heaters



## Finned Heaters

### 375 Finned Strip Heaters

#### Termination Options *(Continued)*

#### Metallic Terminal Boxes - Variations

Metallic terminal boxes are available from stock on offset terminals. Terminal boxes act as a safety feature by covering the terminals. A conduit may be attached to the box through  $\frac{7}{8}$  in. (22.2 mm) diameter holes in the ends of the box. To order, specify **terminal box**.

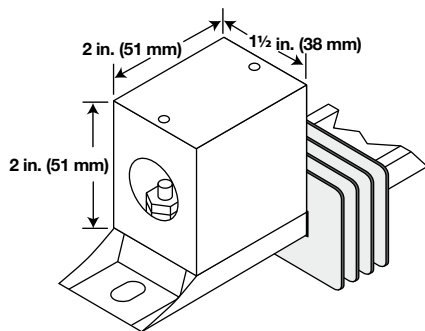

Available on in-line terminals only.

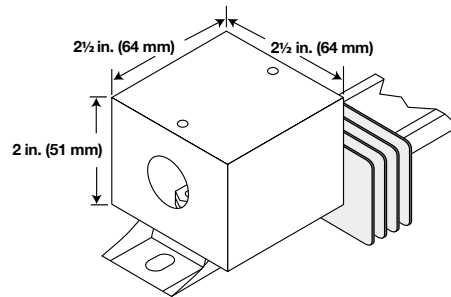

Available on offset terminals from stock and manufactured.

## Accessories

### Secondary Insulation Bushings

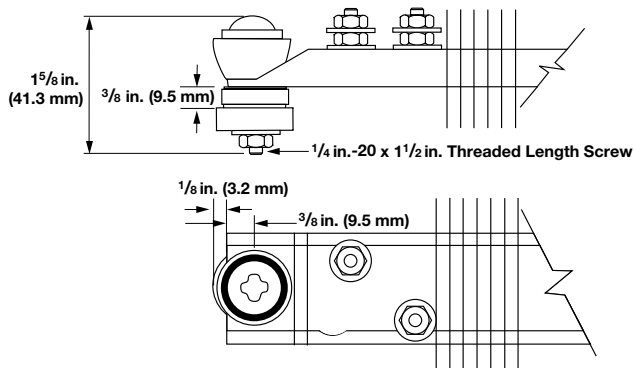

Insulators are suitable when air heating and/or voltage to ground is a concern. A secondary insulation bushing kit, part number **Z-5230**, contains one set of bushings for one heater. To accommodate bushings,  $\frac{17}{32} \times \frac{11}{16}$  inch diameter mounting holes **must** be specified when ordering.

**Note:** Number of fins are dependent on length of heater.

### Ceramic Terminal Covers

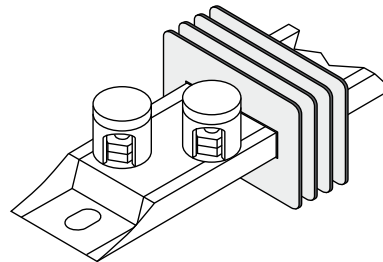

Ceramic terminal covers offer a convenient and economical method to insulate post terminals. A 10-24 screw thread is sized for standard length posts and is supplied as an accessory item and shipped separately. Specify **Z-4918** and quantity.

Sales @ ptsheat.com

Dave Farmery  
Ben Midulla



www.PhoenixThermalSupply.com

Toll Free Phone/Fax

844-787-4328  
844-PTS HEAT

CONTACT: SALES@PTSHEAT.COM; 844-787-4328