

Quick Ship

• Same day shipment on stock units with orders received by 11:00 a.m. CST.

Flexible Heaters

Flexible Shapes and Geometries

Flexible heaters from Watlow are just what the name implies: thin, bendable and shaped to fit your equipment. You can use your imagination to apply heat to the most complex shapes and geometries, without sacrificing efficiency or dependability. With Watlow's customization capabilities, you have the maximum amount of freedom when designing your equipment.

Excellent heat transfer results from the heater's thin design and its direct bonding to the application. Flexible heaters also provide fast heatup and cool down rates, uniform heat distribution and high watt densities.

Features and Benefits

- **Flat geometry** permits holes, notches and unusual shapes.
- **Four material types and two element styles** are available for wider flexibility in meeting your requirements. See next page for performance capabilities.
- **Lightweight construction and low thermal mass** permit use in applications that have limited space or weight requirements.
- **Heating elements** as close as 0.003 inches (0.08 mm) from the heated part respond to controls with faster heat up and cool down.
- **Uniformly spaced element paths**, placed within ¼ inch (6 mm) of the heater perimeter, distribute heat more evenly.

Applications

- Medical equipment such as blood analyzers, respiratory therapy units and hydrotherapy baths
- Satellite and communication equipment
- Freeze protection for military hardware, aircraft instrumentation, hydraulic equipment, etc.
- Battery heating
- Semiconductor equipment
- Foodservice equipment
- Any application requiring a flexible shape or design

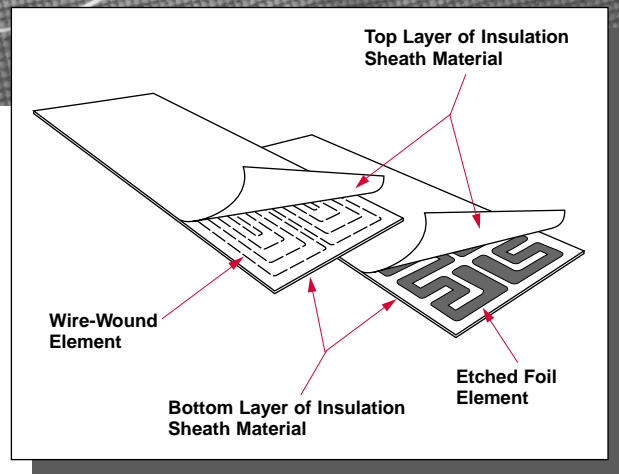
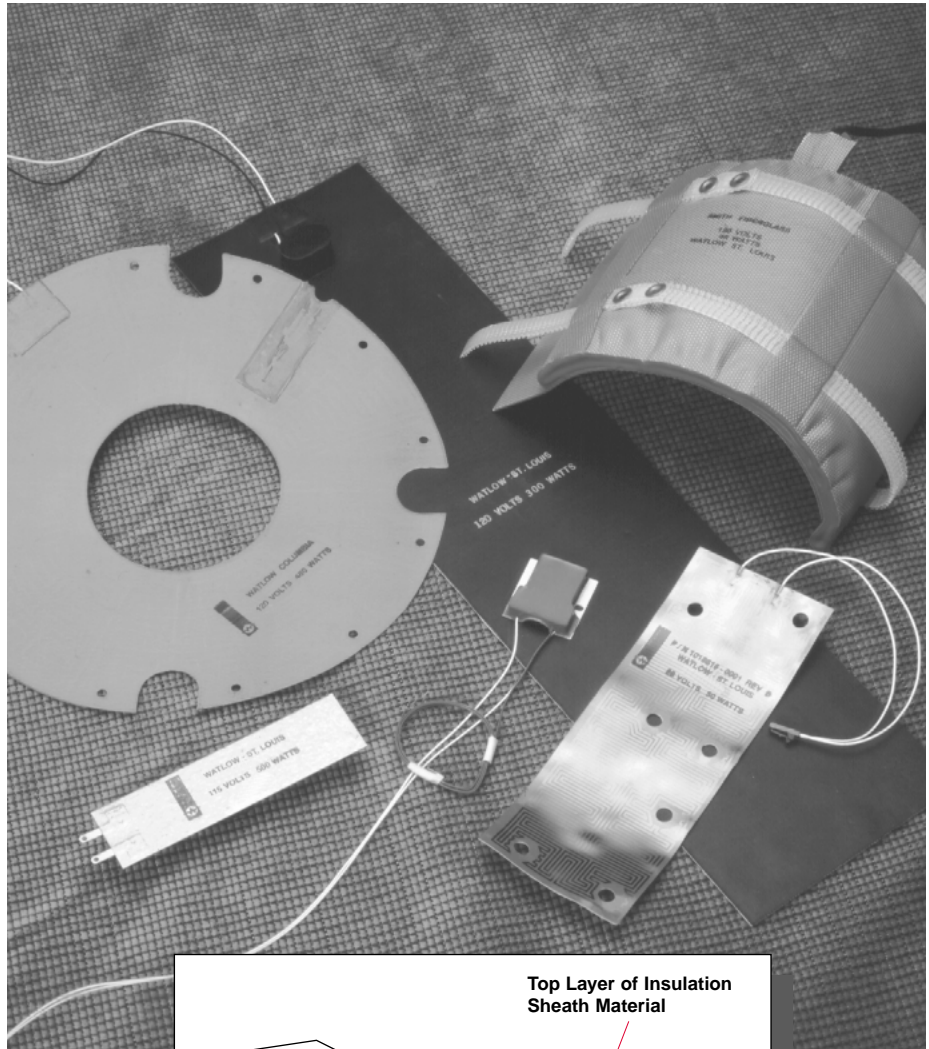

Flexible Heaters

Flexible Shapes and Geometries

Applications and Technical Data

Four Material Types

Silicone Rubber:

This rugged, moisture- and chemical-resistant material is easily bonded or cemented to parts. Watlow silicone rubber heaters can handle temperatures up to 500°F (260°C). Many styles of these heaters are available with UR®, cUR® and VDE recognition. See [page 171](#) for details.

Kapton®:

A thin, lightweight transparent material from du Pont, Kapton® is designed for extremely precise heating requirements ranging from -319° to 392°F (-195° to 200°C). It is ideal for applications requiring low outgassing in a vacuum, or resistance to radiation, fungus and chemicals. Many custom heaters can be UR® and cUR® recognized.

Neoprene:

Neoprene resists weathering, abrasion and chemicals. It can be used economically in applications to 250°F (120°C), where high watt densities are not needed.

HT Foil:

This mica-insulated, high temperature foil is a semi-rigid heater. Operating temperatures up to 1100°F (595°C) can be achieved.



See pages 169 to 182 and 189 to 194 for information on silicone rubber, Kapton®, neoprene, and HT foil heaters.

Two Element Types

Watlow offers both wire-wound and etched foil resistance elements. These element types are available in

most insulating materials, and Watlow can recommend the type best suited to your application.

Wire-Wound Elements

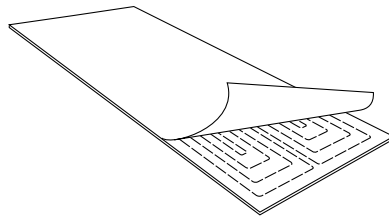

Available on silicone rubber and neoprene heaters, this element style is created by spiraling fine resistance wires around a fiberglass cord. The element is then laid out in a pattern designed specifically for your application. The benefits of wire-wound elements include:

- Excellent physical strength and flexibility; repeated flexing of the heater has no harmful effects on its performance
- Good economy for small production runs
- Conforms readily to curved surfaces, including small radius bends

Drum heaters and conduit bender heaters are typical examples of applications that use the wire-wound method. These heaters are flexed repeatedly during use, but due to their wiring, no internal damage will occur.

Etched Foil Elements

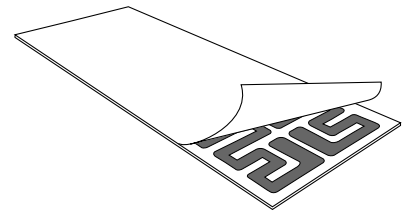

This element type, created by acid etching a circuit in nickel resistance alloy foil, is available in silicone rubber, Kapton® and HT foil heater types. The etched foil element is noted for its excellent circuit pattern repeatability and superior heat transfer, which results from greater area coverage of the element. Other benefits include:

- Delivers more heat and up to twice the watt density of a wire-wound element, providing longer heater life
 - Most economical for large production runs
 - Complex heat distribution patterns can be provided
- The etched foil element style is usually recommended for applications requiring high temperatures or watt densities, or multiple zoning.

Kapton® is a registered trademark of E.I. du Pont de Nemours & Company.

UR® and cUR® are registered trademarks of Underwriter's Laboratories, Inc.

Flexible Heaters

Flexible Shapes and Geometries Options

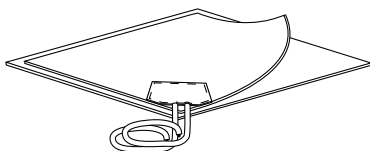

Note: PSAS maximum six months storage life before heater installation.

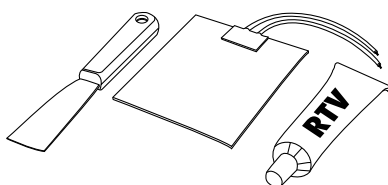

Note: Not recommended for Kapton® heaters.

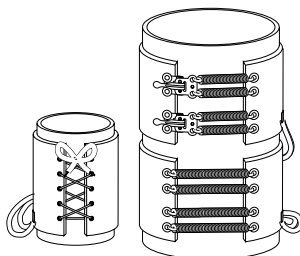
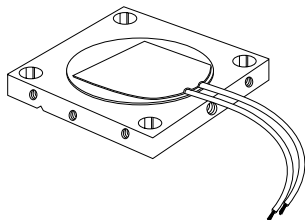
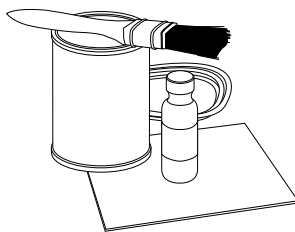

Mounting Methods

Watlow offers various attachment techniques, all designed for fast installation. These include: three types of adhesives; Watlow's special factory vulcanization process; and mechanical fasteners.

Complete installation instructions are available from Watlow. Ask for technical letter #2, silicone rubber heaters.

Pressure Sensitive Adhesive Surface (PSAS)

For speed, convenience and economy of installation, specify **PSAS**. Simply peel off the protective backing and roll the heater in place for an even bond to a clean, smooth surface.

Note: PSAS is not recommended for curved surfaces or for heaters rated above 10 W/in² (0.8 W/cm²). It should not be used for applications exceeding 400°F (205°C) on silicone rubber, 300°F (150°C) on Kapton® or 200°F (93°C) for neoprene.

Field Applied Adhesive (RTV)

For a stronger bond, or when long storage is probable, a **room temperature vulcanizing (RTV) silicone adhesive** is available from stock within two days. Watlow offers red RTV for temperatures up to 500°F (260°C). White RTV is available from adhesive suppliers for temperatures up to 400°F (205°C). Watlow's one-

part RTV is self-priming and can be ordered in either 3 oz (90 ml) or 12 oz (355 ml) tubes. For larger heaters requiring longer adhesive working time, two-part RTV kits can be purchased from adhesive suppliers. These kits require primer on the surface prior to application of the adhesive.

Silicone Contact Cement Kit

This two-part adhesive consists of a resin and catalyst which are easily mixed together and applied with a paintbrush. Recommended usage is for field cementing of silicone rubber heaters to customer parts. Available

from stock, the cement kit will handle temperatures to 350°F (175°C). The resin is available in pint or quart containers. To order, specify **silicone contact cement**, and container size.

Factory Bonding

This attachment technique provides a strong, void-free bond for excellent heat transfer and extended heater life. Watlow's expertise in bonding heaters to customer parts has proven extremely successful.

Bonding is recommended for applications that reach maximum temperatures of 500°F (260°C) on silicone rubber and 300°F (150°C) on Kapton®.

Mechanical Fasteners

When a wire-wound flexible heater must be detachable, any type of fastener normally used with fabrics can usually be built into the sheath material of Watlow flexible heaters. The most common types are latch fasteners, boot hooks and

grommets. Other styles include snap fasteners, springs, velcro style fastener strips and lacing cord. The grommets and boot hooks are commonly used with tension springs to compensate for slight variations in part size.

Flexible Heaters

Flexible Shapes and Geometries

Termination Styles

Watlow offers many types of leads and terminations. Leads can project from any position along the perimeter of the unit. **They will be centered on the short side width of rectangular heaters unless specified otherwise.**

Standard Leads—Type E Teflon®

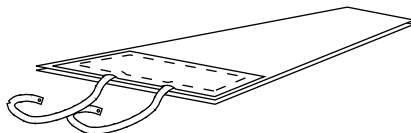

Leads shown exiting end of heater, centered on short side.

Watlow's standard leads are 12 inches (305 mm) long, white, Teflon® insulated, flexible, plated copper wire. They are rated for 392°F (200°C)/600 volts per MIL-W-16878, Type E. The lead connections on or at the heater are insulated with a cap of sheath material, vulcanized to the heater body. All custom flexible heaters except HT foil will be supplied with this lead type unless otherwise specified.

HPN Cord and Plug Set

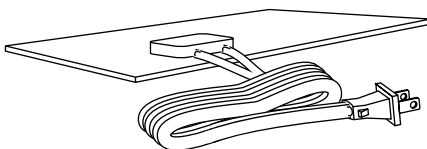

Molded leads are shown exiting edge of heater. Capped leads are also available.

For removable heaters, a six foot (1.8 m) HPN (neoprene insulated) cord and plug set provides convenience. It is rated for 194°F (90°C)/300V~(ac). HPN cord without a plug is also available in any length.

Silicone Insulated Leads

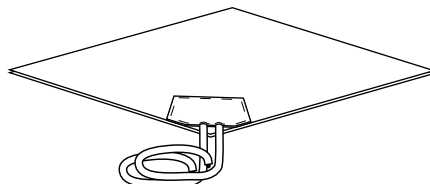

Leads shown exiting corner of heater.

For a better moisture seal, specify UL® silicone insulated lead wires. This lead type is rated for 302°F (150°C)/600V~(ac). Any lead length is available. Note: Silicone rubber heaters are not designed to be waterproof. Excess exposure to moisture may facilitate premature heater failure.

Special Teflon® Leads

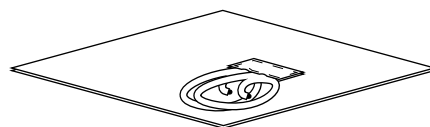

Leads shown exiting middle of heater.

Teflon® leads, UL® style 1180 and cUR® approved, are rated for 392°F (200°C)/300 volts. Any length is available. UL® Teflon® leads are standard on stock rectangles.

Construction

Formed Heaters

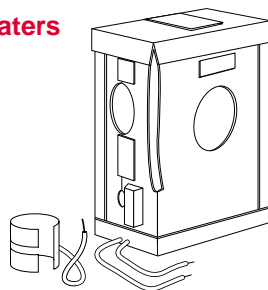

Many three-dimensional shapes, such as cylinders, cones and boxes, can be factory formed. Semi-rigid shapes can be self-gripping to the part. Special tooling may be required for some designs.

Holes, Cutouts and Notches

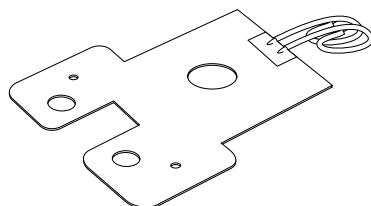

Watlow can provide flexible heaters with special holes, cutouts and notches in nearly any position required for your design. The resistance element can be brought to within 1/8 inch (3 mm) of all edges. Standard spacing is 1/4 inch (6 mm) from all edges.

Teflon® is a registered trademark of E.I. du Pont de Nemours & Company.

Flexible Heaters

Flexible Shapes and Geometries

Temperature Sensors

Watlow offers several styles of sensors for use with flexible heaters. These sensors are available as preset or adjustable thermostats, thermocouples, thermistors, RTDs or thermal fuses. They can be integrally mounted (encapsulated in silicone rubber) to sense the temperature of either the part or the heater sheath. The thermostats can also be ordered separate from the heater, allowing direct control of your process temperature, if desired.

Pre-Set Thermostats

Several styles of non-adjustable, pre-set thermostats are available from Watlow. Thermostats separate from the heater are encapsulated in silicone rubber, and are available with standard 12 inch (305 mm) leads unless otherwise specified.

Thermocouples, thermistors, RTDs and thermal fuses are usually mounted to the heater under a vulcanized protective cap of silicone rubber sheath material. This drawing shows a typical mounting style for a thermocouple.

Note: Precise part temperature control with preset thermostats requires prototyping and field testing.

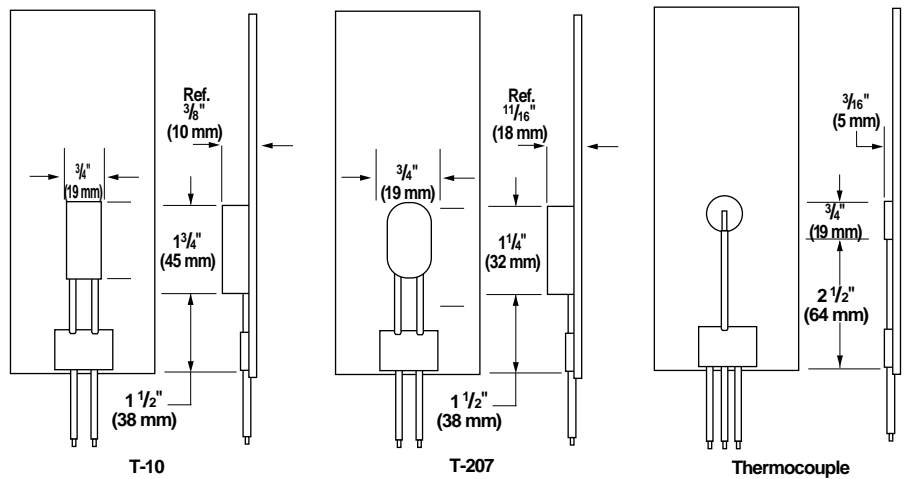

Pre-Set Thermostats (Non-Adjustable)

Thermostat Model	Maximum Watts	Volts AC	Temperature Settings Available °F (°C)	Agency Approvals		
				UR	cUR	VDE
T-10	600/960	120/240	125-300±10 (50-149±5)	yes	yes	yes
T-207	1500	120/240	40/55±8 (4/13±4.4)	yes	yes	yes
	1500	120/240	60/75±8 (16/24±4.4)	yes	yes	yes
	1500	120/240	95/110±8 (35/43±4.4)	yes	yes	yes
	1500	120/240	145/160±8 (63/71±4.4)	yes	yes	yes

Notes:

- When ordering a pre-set thermostat separate from the heater, simply add the prefix **S** to the model number. (Example: ST-10) See next page.
- Snap action preset temperatures on the T-207 are close/open settings.
- T-10 thermostats are manufactured for specific preset temperatures. Available in 25 F increments.
- Other temperature ranges and voltages are available on special order. Minimum quantities apply, so consult factory before ordering.

Adjustable Thermostats

The B-200 thermostat features a maximum rating of 1500 watts at 120/240V~(ac). The following temperature ranges are available:

- Model B-200-2: 100° to 500°F (40° to 260°C)

- Model B-200-3: 25° to 330°F (-5° to 165°C)

The B-200 thermostat can be integrally mounted to the heater with a bonded protective cap of silicone rubber sheath material.

Flexible Heaters

Flexible Shapes and Geometries

Temperature Sensors

Continued

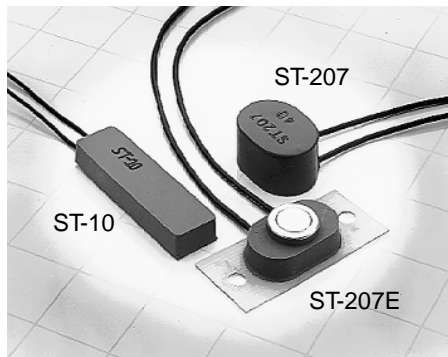

Separate Heater Accessories Available From Stock

Pre-Set Thermostats Separate From Heater

These are offered to allow direct control of your process temperature, so you're not limited to controlling only the heater temperature when using stock heaters. Pre-set thermostats are encapsulated in silicone rubber with standard 12 inch leads.

The same temperature ranges, ratings and sizes are available on these thermostats. When ordering, add "S" prefix to the model number to indicate "separate" item. (Examples: ST-10 and ST-207)

Standard leads are 12 inch (305 mm) 18 ga. UL1180 black leads.

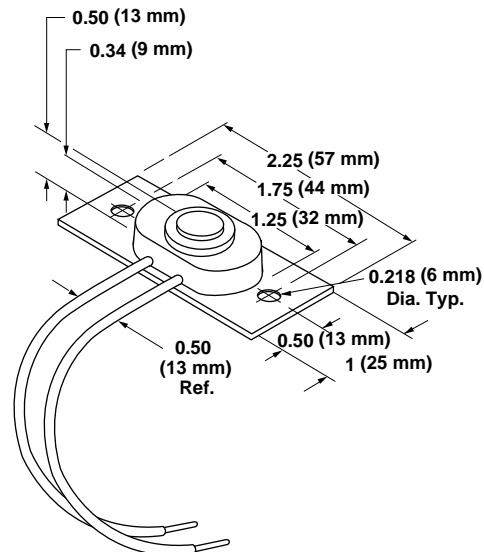

Notes: For direct control of air temperature as is required in enclosure heating applications, specify thermostat model number ST-207E. This is a modified ST-207 mounted on 1/2 inch thick G-10 circuit board with the thermostat's metal cap exposed to sense air temperature.

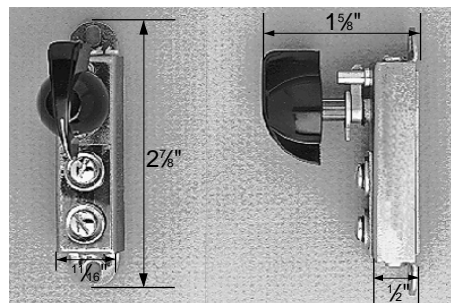

B-200

Adjustable Thermostats Separate From Heater

The Model B-200 adjustable thermostat can be ordered as a separate item. The same model numbers and temperature ranges

indicated under *Adjustable Thermostats* are available. When ordering, simply note that you want the **B-200 separate** from the heater.